

System drawings shown in this bulletin are for illustration purposes only. Refrigeration systems should only be serviced by a qualified technician. Always observe proper safety procedures when servicing a refrigeration system. For more information see the latest revision of Phillips Safety Bulletin SGRV.

Description of Operation

The 101 Series valves modulate the flow of liquid refrigerant in direct response to the movement of the float ball immersed in the liquid. The float ball is linked through the forked lever to act upon the needle or plunger directly over the orifice controlling the refrigerant flow. A spring is interposed over the needle, working in opposition to the lever, which tends to support the weight of the float ball. The spring pressure can be regulated by an adjusting stem to make the float lighter or heavier, causing the liquid level to be respectively lower or higher to any desired point within the range of the spring. Turning the adjusting stem counter-clockwise will raise the liquid level. Turning the stem clockwise will lower the level. Total level change, at a particular setting, from a fully closed to a fully open valve is about 2" on the 101 and 101A valves, and about 2-1/2" on the 101AB and 101B valves. The 101AB and 101 B valves have been discontinued, but some parts are still available.

The 101 valve is also used as a pilot float valve for the 701S Series low side pilot operated liquid feed valves. The valve may then be designated 101VP18 (for 701JR and 701S valves), or 101VP26 (for 701AS and 701BS valves). When used for halocarbons, a suffix "F" is added after the "VP" to denote a heavier ball and a seal cap over the stem.



Installation

Protect the needle and seat by installing a strainer ahead of the valve. On an ammonia installation the lower (liquid) balance line should not be allowed to trap oil. If it becomes necessary to loop the lower balance line, an oil pot must be installed at the lowest point, and the liquid equalizing line should come out the side of the pot to insure a true liquid level. The oil pot should be periodically drained.

Before installing the chamber, open the top flange and remove the wire on the float ball. Make sure the float ball moves freely from top to bottom without excessive friction or binding. Be sure that the lever is straight.

Figure 1: Typical Installation

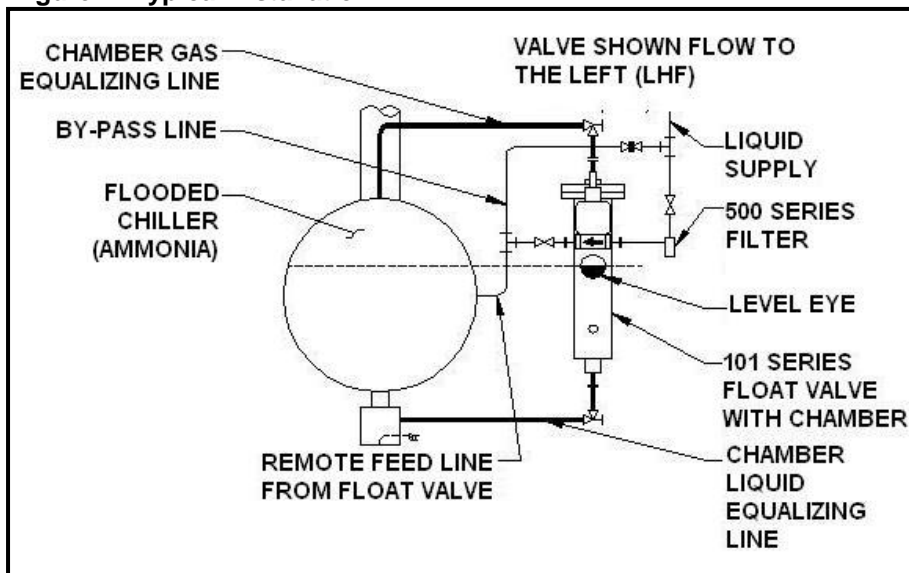

Adjusting for Initial Operation

To start, back the stem out fully. Open the liquid line hand valves to secure the flow through the valve. Now turn the stem down until the feed stops, and then back off until the liquid level is secured. Any further adjustment to secure a higher or lower liquid operating level may be made after the equipment is in operation for a time. Turning the stem clockwise will lower the level, while turning the stem counter-clockwise will raise the level.

Table 1: Valve Capacities - Tons

Valve Number	Orifice (in.)	Cv	Ammonia (R-717)					R-22					Total Pressure Drop Limit – PSIG**	
			Inlet Pressure – PSIG					Inlet Pressure – PSIG					R-717	Halo-carbon
			80	100	125	160	200	80	100	125	160	200		
101	5/64	.14	7.4	7.8	9.1	9.9	11	1.8	1.9	2.1	2.3	2.4		
	3/32	.18	9.3	11	11	12	14	2.4	2.5	2.7	2.9	3.2		
	1/8	.29	15	17	18	20	23	3.8	4.0	4.3	4.7	5.1		
	5/32	.34	18	19	22	24	27	4.4	4.7	5.0	5.5	5.9		
	3/16	.47	25	27	30	33	37	6.1	6.4	7.0	7.7	8.2		
101A	3/16	.55	29	32	36	39	44	6.9	7.4	8.0	9.2	9.7		
	1/4	.96	51	55	62	68	76	12	13	14	16	17		
	5/16	1.1	58	63	71	77	87	14	15	16	18	19	160	190
	3/8	1.4	73	79	89	97	109	18	19	21	22	24		
101AB*	3/8	1.5	79	86	96	105	118	19	21	22	24	26		
	7/16	1.8	95	103	116	126	142	23	25	27	29	31		
	1/2	2.2	116	125	142	155	-	29	30	33	36	38	180	
	5/8	2.7	143	154	-	-	-	35	37	40	43	47	115	
101B*	3/8	2.0	106	114	129	141	158	26	28	30	33	35		
	7/16	2.4	127	137	155	169	189	31	33	36	39	42		
	1/2	3.2	169	182	213	225	252	42	44	48	52	56	180	
	5/8	4.0	212	228	258	281	315	52	55	60	65	70	115	

* The 101AB and 101B valves are discontinued.

** All valves function properly at maximum pressure drop of 230 PSIG except as indicated.

ALTERNATE REFRIGERANT RATINGS

R-22 Nominal Capacity Multipliers	
R-134a	0.82
R-404a	0.74
R-410a	1.10
R-507a	0.82

LIQUID SUB-COOLING FACTORS

°F of Sub-cooling	5	10	20	30	50
Factor	1.25	1.47	1.75	1.9	2.2

Figure 2: General Drawing with Item Numbers

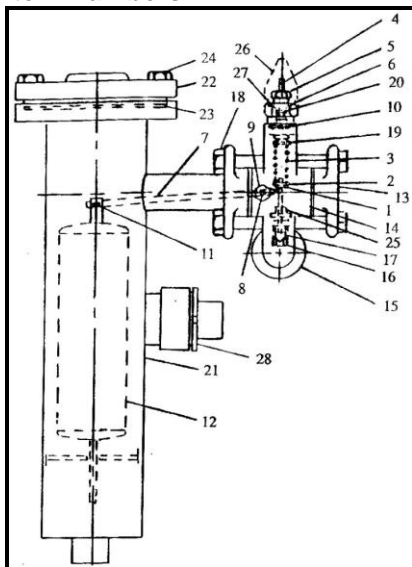

This cut-away drawing is general for 101 Series low-side float valves with chambers. The numbers shown refer to item numbers in the parts tables on the next page.

Figure 3: 101 and 101A Valves with Cartridge

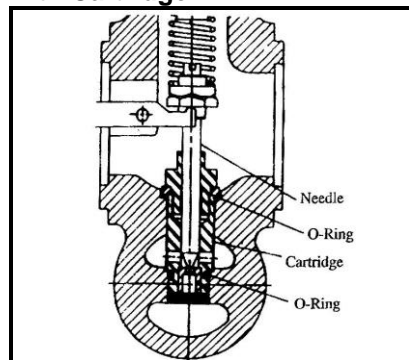

The cartridge will replace old style seat bushings and glands of the type still used on the 101AB and 101B valves.

Figure 4: 101 and 101A Valves Prior To Use of Cartridges

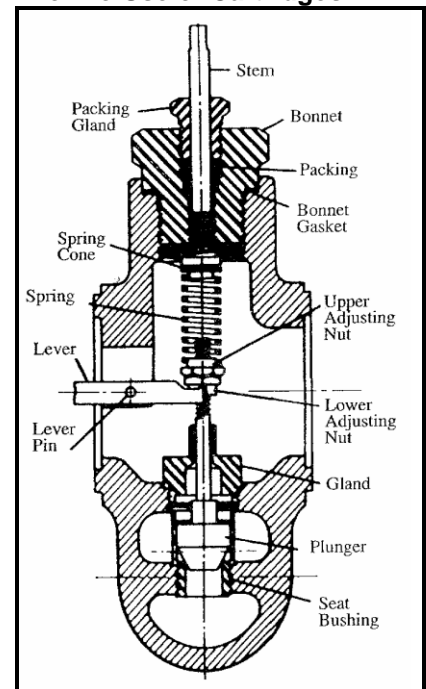

101AB and 101B valves are as shown above. New type cartridges can be used in all 101 and 101A valves.

Replacement Parts

Table 2: Replacement Parts

ITEM NO.	DESCRIPTION	101 101VP18 101VPF18 101F 101F18	101CPS 101CPSF	101VP26 101VPF26	101A 101AVP18 101AF	101AB 101ABF	101B 101BF
						These valves have been discontinued, but some parts are still available.	
1	Adjusting Nut, Lower	4	4	4	4	4	4
2	Adjusting Nut, Upper	4	4	4	4	4B	4B
3	Spring R-717	5-2A	5-30A	5-30A	5-30A	5-AB-45	705-A
	Halocarbons	5-30A	5-60L	5-60L	5-61	705A-114	705A-114
4	Stem	7	7	7	7	7-B	7-B
5	Packing Gland	8	8	8	8	8-B	8-B
6	Bonnet	9F	9F	9F	9F	9BF	9BF
7	Lever	10	10-CPS	10	10	10B	10B
8	Lever Pin	11	11	11	11	11B	11B
9	Pipe Plug, Hex Head	12	12	12	12	12	12
10	Gasket, Bonnet	19	19	19	19	19B	19B
11	Cotter Pin	56	56	56	56	56	56
12	Float R-717	67-8	331-15	67-16	68-8	68-12	69-12
	Ball Halocarbons	67F-8	331-15F	67F-16	68F-8	68F-12	69F-12
13	Blind Flange	61F	61F	61F	61F	71F	71F
14	Gasket, Valve (2)	63	63	63	63	73	73
15	Valve Body	101-1/2	101-1/2	101-1/2	101A-3/4	102-1	102-1¼
16	Cartridge or Seat*	152K**	152K** or 152L**	152K**	152L**	152B	152B
17	Needle or Plunger*	153	153	153	153A	153B	153B
18	Cap Screw, Valve (8)	62	62	62	62	1459	1459
19	Spring Cone	6	6	6	6	708-A	708A
20	Packing Ring	775	775	775	775	777BN	777BN
21	Chamber	1350-18	-	1350-26	1450	1450-AB	1550
22	Flange, Chamber	1351-1	-	1351-1	1451-1-1/4	1451-1-1/2	1551
23	Gasket, Chamber	1358	-	1358	1458	1458	1558
24	Cap Screw, Chamber	718 (8)	-	718 (8)	1459 (8)	1459 (8)	1559 (12)
25	Gland	-	-	-	-	151-B	151-B
26	Seal Cap (Halocarbons)	714	714	714	714	714B	714B
27	Gasket, Seal Cap	720	720	720	720	720B	720B
28	Level Eye®	See Engineering Bulletin 1100 for Level Eye replacement parts.					
-	*Spare Parts Kit Includes Item # 3, 10, 14, 16 (Specify orifice diameter when ordering)	K152K (101 & VP18) K152KF18 (101F & 101VPF18) K152LF18 (101F18)	K152KCP K152LCP (101CPS) K152KCPF K152LCPF (101CPSF)	K152K26 K152KF26	K152L (101A) K152L18 (101A18) K152LF (101AF)	K101AB K101ABF	K101B K101BF

** 152K and 152L are cartridges, and include the 153 and 153A needle and plunger respectively.

Changing Cartridge: Needle & Seat

The life of the needle or the plunger and orifice seat depend upon operating conditions. An orifice too large for the maximum load, or sub-cooled liquid supply, may cause the valve to operate at some intermediate position or with barely open orifice at low load. This can cause excessive wire-drawing of the needle. Also, flash gas in the liquid line is a major cause of wire drawing. When it becomes necessary to change the cartridge, the procedure is as follows:

Close the liquid line hand valves on each side of the 101 valve and close the upper chamber equalizing valve. Allow the chamber to purge itself before closing the lower balance line valve. Finish venting with pump out valve. After pump-out, remove the bonnet assembly, spring cone, spring and blind flange at the face of the valve. Remove the lever pin after first removing the 1/4" pipe plug at the side of the valve. From the front of the valve, use long-nose pliers to grasp the lever fork, pull down, and push the lever back into the semicircular cavity in the valve casting.

Remove the needle with adjusting nuts (on valves so equipped), then remove the gland. On 101AB valves and larger, it is necessary to remove the gland with plunger attached. Valves equipped with cartridges require only a 5/8" open-end wrench to remove the entire seat and needle assembly. Only type 101 and 101A valves have cartridge type construction. On older 101 and 101A valves, and on all 101AB and 101B valves, it is necessary to remove the seat bushing with a screwdriver-type tool. The cartridge type 101 and 101A valves have been used since 1955, and the cartridge will fit all 101 and 101A valves in the field.

Remove the adjusting nuts and install them loosely on the new needle. Apply O-ring grease to the cartridge O-rings. Insert the cartridge type assembly without using dope, since O-rings will seal by pressure only. A good grade of non-hardening pipe dope should be used on seat bushings not equipped with O-rings. Replace the gland on 101AB and 101B valves with the plunger and adjusting nuts. Pull the lever into position and insert the lever pin.

Before setting the valve, refer to the table below for the proper number of turns required.

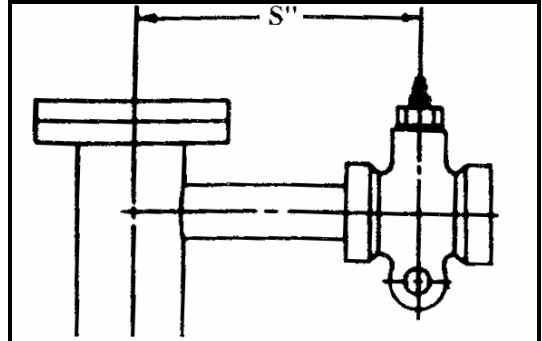

Valve	S	Turns
101, -F, -V, -VP	9-1/2	2-1/2
101-F, -V	7	4
101-A, -AF, -AV, -AVP	9	3
101-AF, -AV	7	5
101-AB, -ABF, -ABV	16-1/4	3
101-B, -BF, -BV	16-1/2	4
101-BF, -BV	11-1/2	6
101-CPS, -CPSF	8	2

To set the valve movement, hold the needle down firmly with a screwdriver. Screw down the lower adjusting nut until it just touches the forks. Screw the upper nut down all the way but do not tighten. In this position, hold the lower adjusting nut with an open end wrench, and, noting the position of the screwdriver, turn the screwdriver counterclockwise the number of turns indicated for the particular valve according to the "S" dimension. Holding in this position, tighten the upper nut against the lower nut, using two wrenches.

Replace the spring, spring cone, and bonnet assembly. Replace the pipe plug on the lever pin using 60 ft-lbs torque and Teflon pipe thread sealant. Replace the front blind flange, and the valve is now ready for operation.

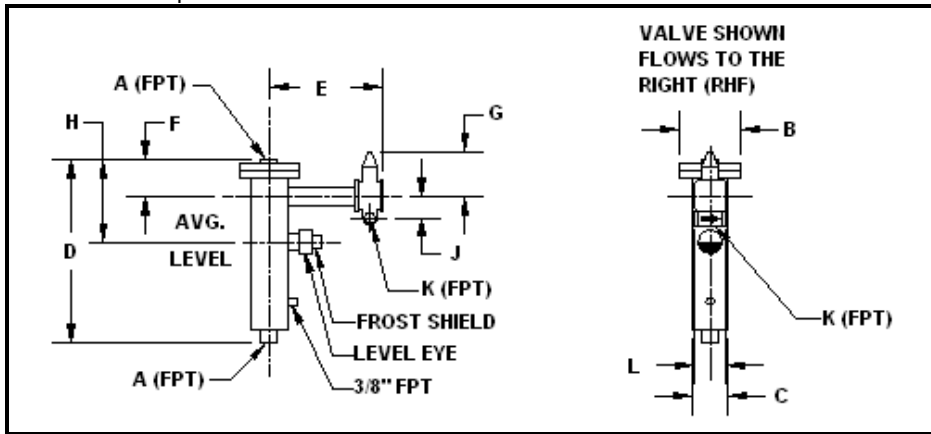

Valve Number*	Dimensions (in.)											Weight ** (lbs.)
	A (FPT)	B	C	D	E	F	G	H	J	K (FPT)	L	
101	1	6-1/2	4	19-1/2	12-3/8	4	5-7/8	9	2-3/8	1/2	3-1/2	60
101A	1-1/4	8-3/8	5-9/16	20	11-7/8	4-1/2	5-7/8	9-1/2	2-3/8	3/4	3-1/2	85

* 'F' suffix on valve number indicates use with halocarbon refrigerants. Assembled with a heavier float ball and spring.

** Shipping weight including chamber.

H. A. Phillips & Co.
 770 Enterprise Avenue
 DeKalb, IL 60115 U.S.A.
 Phone: (630) 377-0050
 Fax: (630) 377-2706
 101-SB18-02

